

Turntable TT 8.0 - 10t

Technical data:

Diameter	8.0 m
Load capability	10000 kg
Point load	1250 kg at 10 cm x 10 cm
Height	1000 mm
Material cover plate	Stainless steel
Rotating speed adjustable	0.1 rpm – 1.0 rpm
Positioning accuracy	+/- 0.5°
Rotating angle	-200° to 400°
Motor	Synchronous servo motor
Turntable drive	Helical-bevel gear
Elevation tolerance	< 3 mm
Gap between TT and the surrounding	< 5 mm
Concentricity tolerance	+/- 1 mm
Ground plane connecting	every 50 mm
Square border interface (easy fitting into ground plane of chamber)	8.5 m x 8.5 m
Voltage	380 VAC – 480 VAC, 50 Hz / 60 Hz, three phases
Current consumption	max. 32 A
Required RCD	300 mA
Control cable	Fiber optic lines
Remote control via	LAN (TCP/IP); (IEEE only with NCD)
Interference suppression	20 dB under limits DIN EN 55011:2018-05 class B
Temperature working range	10° C – 35 ° C
Total weight	approx. 15000 kg
Accessories	Service manual Standard CP equipped with: - 2x Schuko 230V/16A - 1x CEE 400V/16A 3 phase

Sales Partner:



Phone: +49 (0)9606 923913-0
Fax: +49 (0)9606 923913-29

ABSOLUTE EMC LLC.
Covering sales in North America
United States, Mexico, & Canada

eMail: info@matur-gmbh.de
Web: www.matur-gmbh.de

absolute-emc.com
Phone: 703-774-7505
info@absolute-emc.com

Brief description

The turntable TT 8.0-10t is especially designed for flush mounted installation in semi anechoic electromagnetic absorption chambers. The carrier plate is made of stainless steel.

The LAN (TCP/IP) - interface provides an additional control option for all functions, when operated with the FCU^{3.0} or NCD Controller.

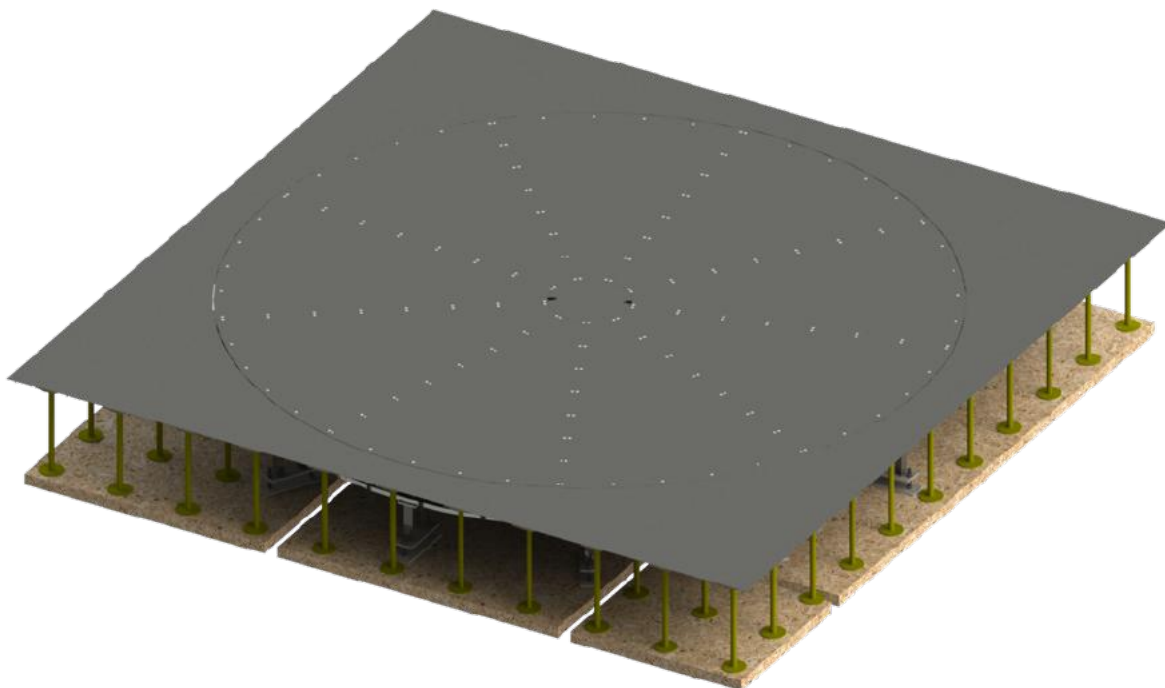

Power supply in the turntable center

It is possible to integrate various types of connectors for the power supply of the EUT. A standard 500 mm diameter opening in the center of the turntable provides the capability to insert power supply for testing, other diameters on request.



Standard center plate



Example for a customized center plate

Sales Partner:



Phone: +49 (0)9606 923913-0
Fax: +49 (0)9606 923913-29

ABSOLUTE EMC LLC.
Covering sales in North America
United States, Mexico, & Canada

eMail: info@matur-gmbh.de
Web: www.matur-gmbh.de

absolute-emc.com
Phone: 703-774-7505
info@absolute-emc.com

Rotary encoder and limit switch

The turntable is equipped with a rotary encoder to guarantee the exact positioning of the turntable.

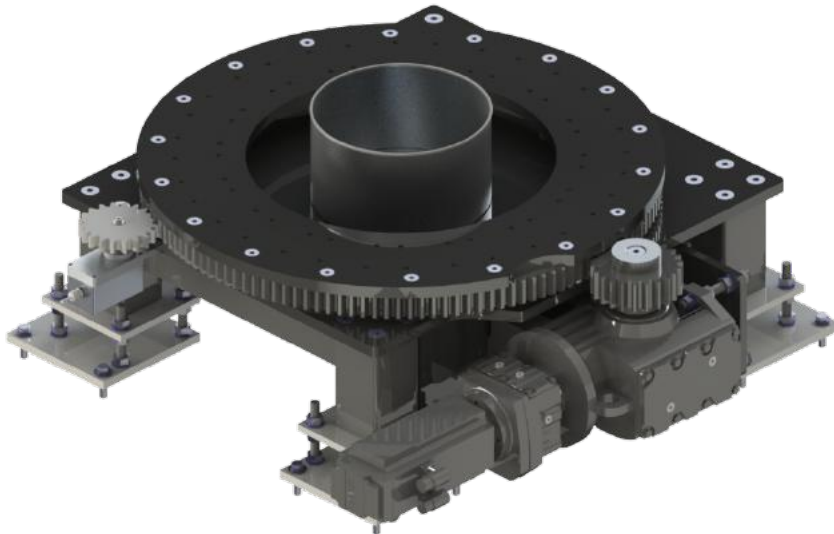

Rotary encoder and limit switch system

Connection to ground plane

A long-lasting, maintenance-free contact system is included, which is made by hollow core copper beryllium tubing.

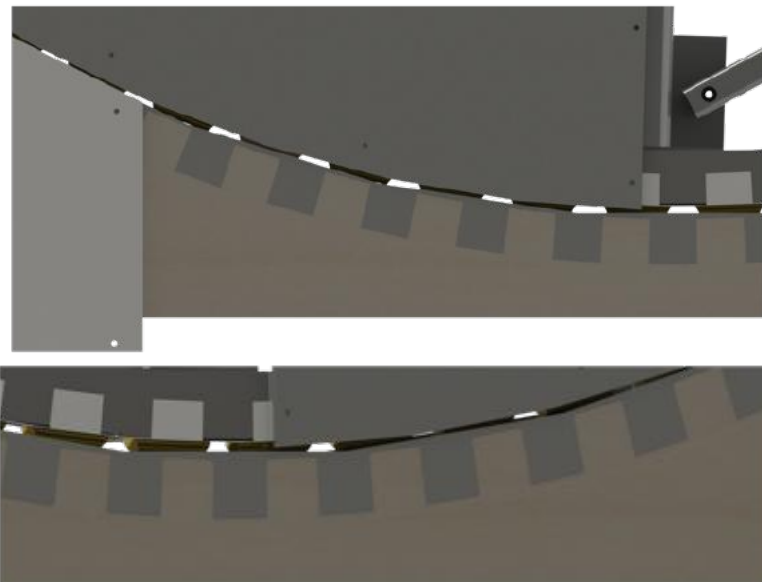

Contact system between the turntable and the surrounding

Sales Partner:



Phone: +49 (0)9606 923913-0
Fax: +49 (0)9606 923913-29

ABSOLUTE EMC LLC.
Covering sales in North America
United States, Mexico, & Canada

eMail: info@matur-gmbh.de
Web: www.matur-gmbh.de

absolute-emc.com
Phone: 703-774-7505
info@absolute-emc.com

Turntable structure:

Solid welded steel construction; parts are assembled with screws (for easy transportation).
The complete structure is either pre-coated and painted or galvanised for long-lasting performance of the system.



Turntable structure made of solid welded steel

Further specifications and options available upon request

The following options are available upon request:

- Power supply in the centre with different connectors
- External power supply outside the centre with energy chain
- Continuous rotation with integrated slip rings or rotary joints
- Integrated exhaust gas extraction system
- Integrated cooling fan system
- Vehicle charging possibility
- Maintenance hatch
- Higher positioning accuracy
- Outdoor applications

Information presented enclosed is subject to change as product enhancements are made regularly. Pictures included are for illustration purposes only and do not represent all possible configurations.

Sales Partner:



Phone: +49 (0)9606 923913-0
Fax: +49 (0)9606 923913-29

ABSOLUTE EMC LLC.
Covering sales in North America
United States, Mexico, & Canada

eMail: info@matur-gmbh.de
Web: www.matur-gmbh.de

absolute-emc.com
Phone: 703-774-7505
info@absolute-emc.com